

Cal. AD988

Ø 18.50 mm

H 3.15 mm

Item	Version No
Specification	Version 1
Appearance	Version 1
Casing	Version 1
Hand Fitting	Version 1
Hands	Version 1
Hand Setting Stem	Version 1
Dial - 1	Version 1

Movement Specification

AD988 6_{3/4} x 8^{1/8} Quartz Movement 3 Hands

1.MOVEMENT DIMENSIONS

- Outside diameter $\varnothing 18.2\text{mm} \times 15.3\text{mm}$
- Total height 3.15mm

2.TIME STANDARD

- Frequency of quartz oscillator 32768Hz
- Accuracy Monthly rate: Less than ± 45 seconds per month at normal temperature range

3.BATTERY

- Type Silver oxide battery
- Size $\varnothing 6.8 \times t 2.6(\text{mm})$
- Recommended battery SR626SW

4.OPERATING TEMPERATURE RANGE From $-5^{\circ}\text{C} \sim 50^{\circ}\text{C}$

5. OPERATING VOLTAGE 1.25V~1.65V

6.AVERAGE OPERATING CURRENT $2.2\mu\text{A} \sim 2.5\mu\text{A}$

7.OUTPUT TORQUE OF SECOND HAND $\geq 5.5\mu\text{Nm}$

8.The diameter of the dial leg $\varnothing 0.70(\text{mm})$

Appearance

AD988

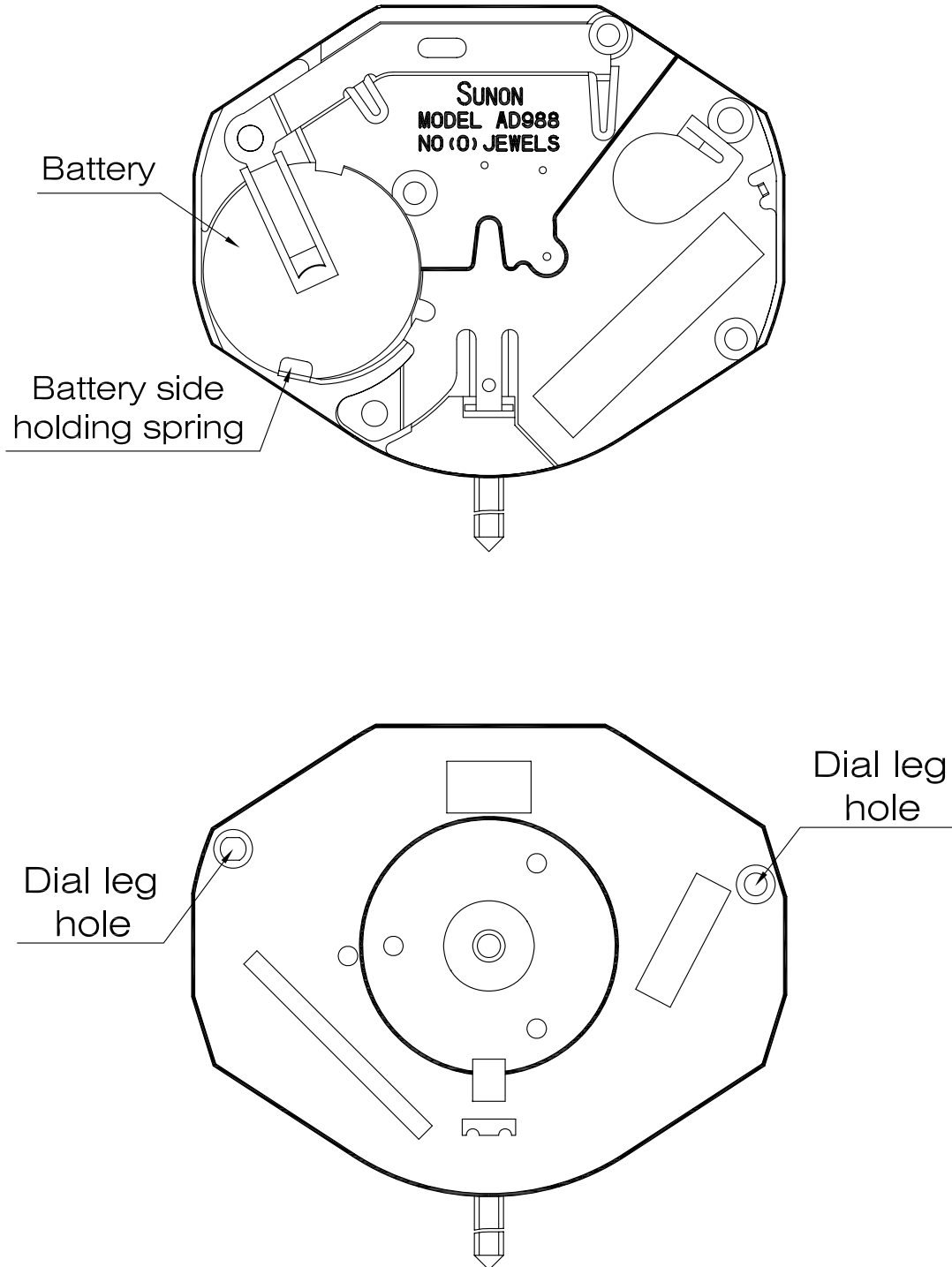

Scale : 4:1
Unit : mm

Version: 1

Casing

AD988

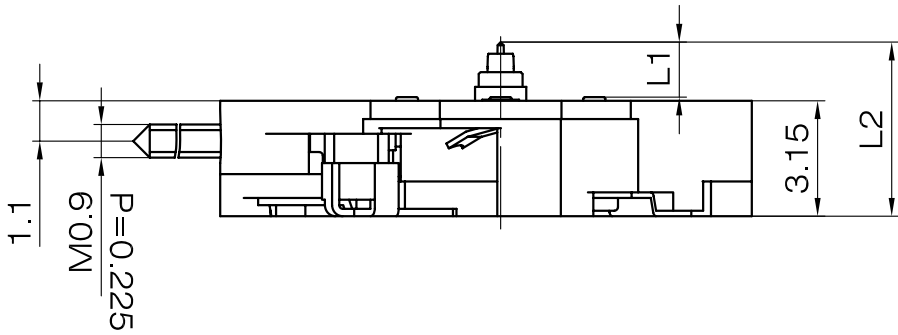

Center post	Height	
Maximum height from main plate surface	L1	1.6
Total height incl. movement	L2	4.75

Hand Setting Stem	A	B
L1	19.2	21.7

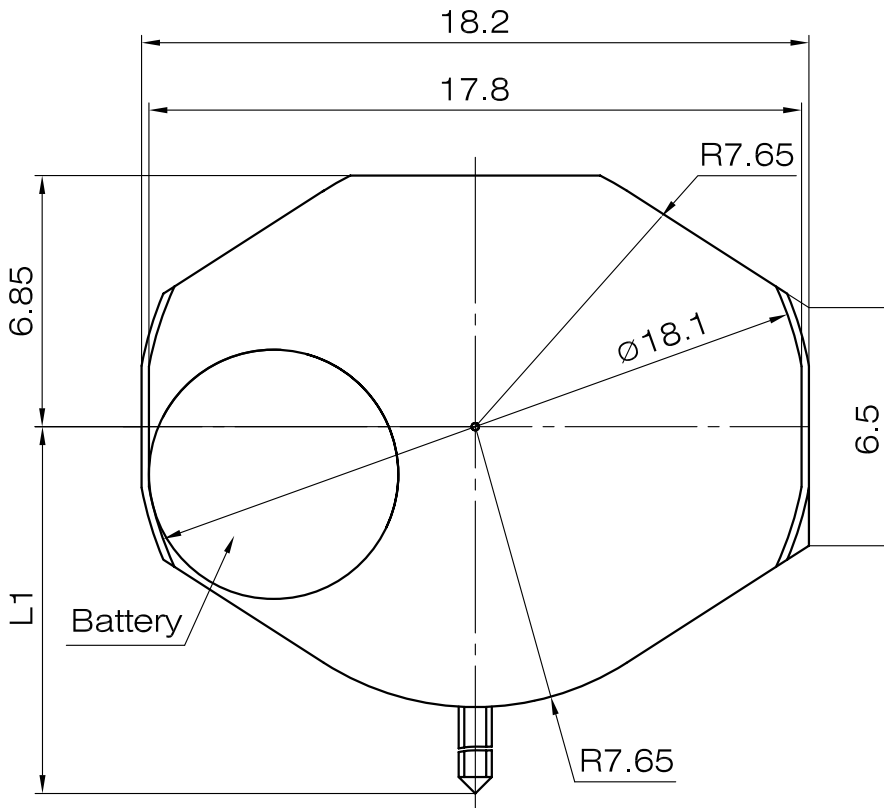

Scale : 4:1
Unit : mm

Version: 1

Hand fitting

AD988

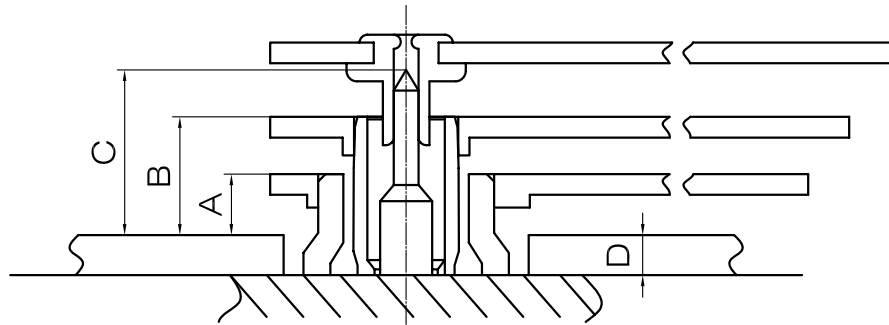
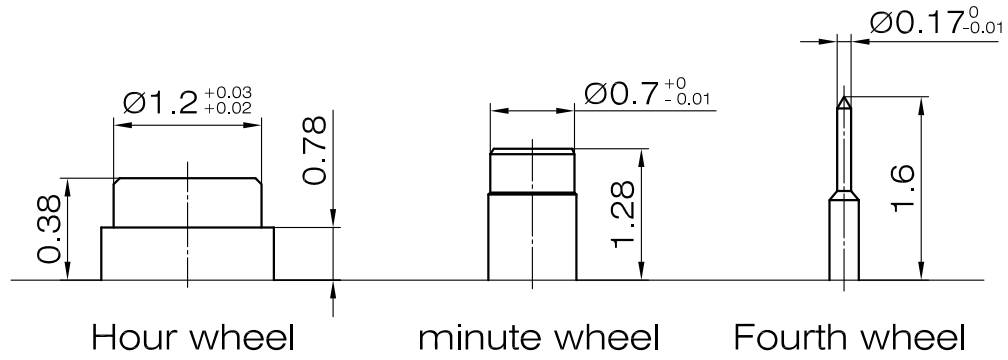

	A	B	C	D
height	0.38	0.88	1.2	0.4

Scale : 20:1
Unit : mm

Version: 1

Hands

AD988

SECOND

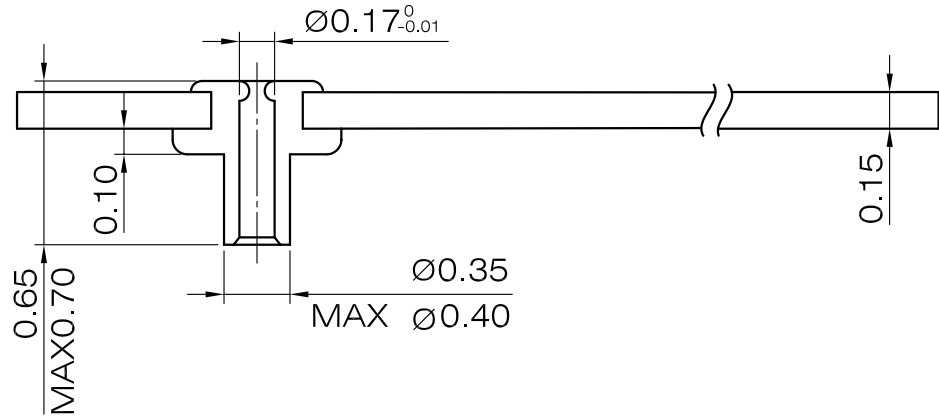

MINUTE

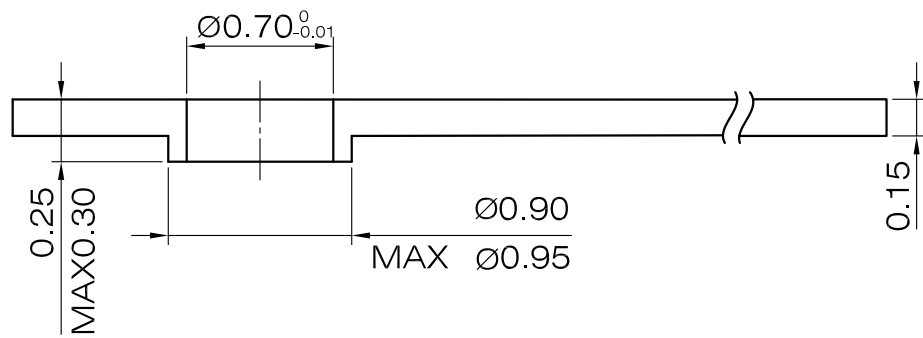

HOUR

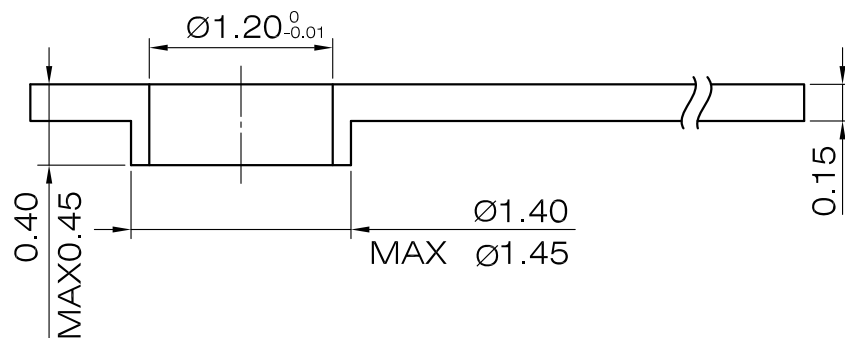

Scale : 20:1

Unit : mm

Version: 1

Hand Setting Stem

AD988

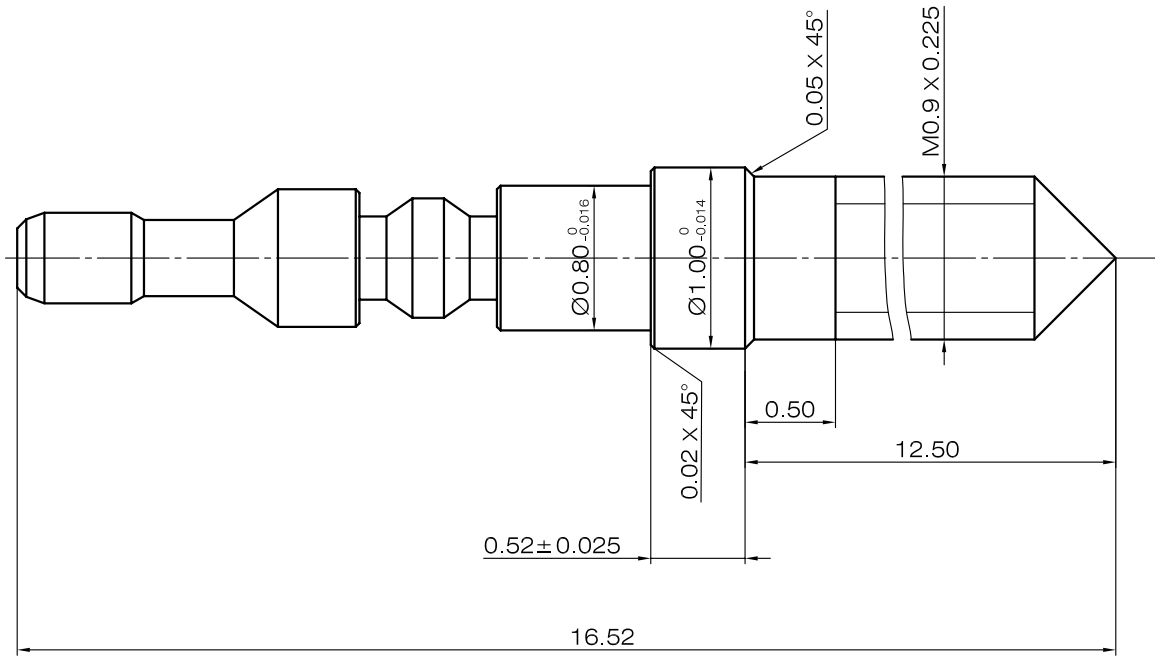

Scale : 20:1
Unit : mm

Version: 1

Dial - 1

AD988

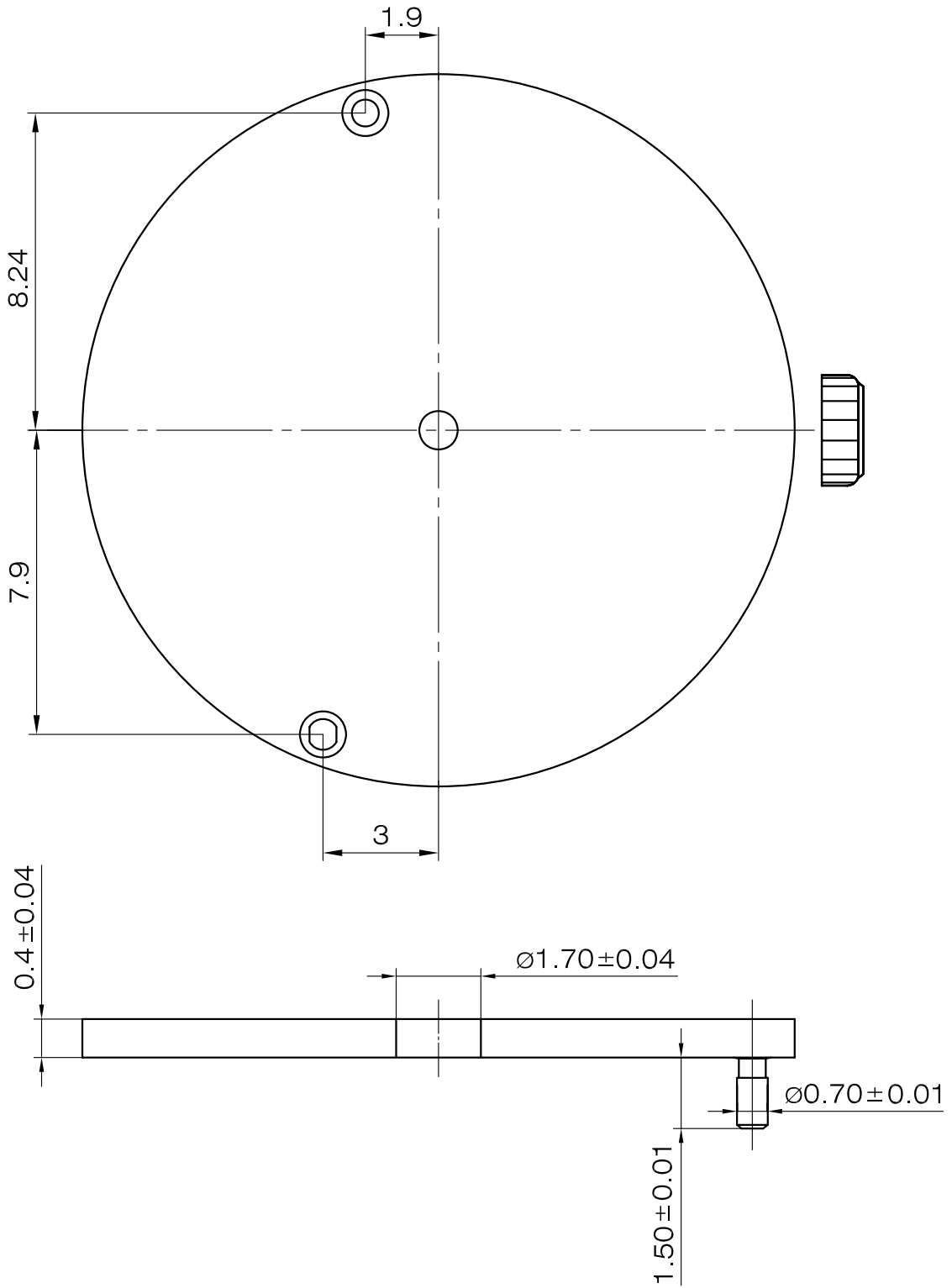

Scale : 7:1
Unit : mm

Version: 1